

DMU02 Dynamics Measurement Unit



GENERAL DESCRIPTION

The DMU02 combines MEMS angular rate and linear acceleration sensors to create a simple to use six-degrees-of-freedom dynamics measurement unit for complete motion sensing and control in three-dimensional space.

Using Silicon Sensing's proven MEMS ring gyro technology the DMU02 offers unsurpassed accuracy and reliability in an affordable and compact package. Angular rate and acceleration data is supplied by the DMU02 every millisecond to meet the needs of highly responsive control systems.

The DMU02 provides a cost-effective solution for a wide range of applications requiring a complete six-degrees-of-freedom motion sensing module.

DMU02 is simple to mount via 2 screws, optional alignment dowels and an 8-pin connector.

The SPI industry standard 4-wire interface provides access to the following data:

- Roll, pitch and yaw angular rates
- Longitudinal, lateral and vertical acceleration

USB based development equipment is available.

FEATURES

- A compact six-degrees-of-freedom module, providing Roll, Pitch, Yaw angular rate plus Longitudinal, Lateral and Vertical translational acceleration
- Benchmark bias and scale factor performance
- Full scale dynamic range $\pm 300^\circ/s$ and $\pm 6g$

- Robust MEMS based strapdown system
- 1 cubic inch unit
- +5V supply
- Comprehensive Built In Test (BIT) for Angular Rate and Communication functions
- 4 wire industry standard SPI interface
- RoHS compliant

APPLICATIONS

- Platform stabilisation and control
- Air, sea and land applications
- Robotics
- Antenna stabilisation
- Vehicle dynamic sensing
- Navigation aiding
- Autonomous vehicles (ROVs and UAVs)
- Laboratory
- Biomechanics

ORDERING INFORMATION

Model	Angular Rate Bandwidth	Angular Rate Range	Acceleration Bandwidth	Linear Acceleration
DMU02-01-0100	40 Hz	300°/s	400Hz	$\pm 6g$

Model	Description
USB01-00-0100	USB development equipment

FUNCTIONAL BLOCK DIAGRAM

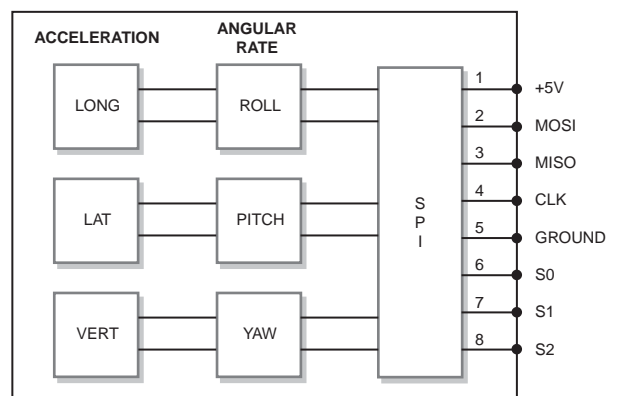

C.G. 18327

Contents	Page
General Description	1
Features.....	1
Applications	1
Ordering Information	1
Functional Block Diagram	1
Absolute Maximum Ratings	3
Normal Operating Ratings	3
ESD Sensitivity	3
Environmental Requirements.....	3
Radiated immunity BS EN61000-6-1	3
Radiated emissions BS EN61000-6-3	3
Specification	4
Product Description	5
DMU02 Operation	5
Mechanical Configuration	5
Product Labelling	7
Connector pin-out	7
Operation and Timing Specification	7
Serial Peripheral Interface Port.....	7
External System to DMU02 Messages	9
Self Test Capability	10
CBITA Function (Command BIT 3).....	10
Product Environmental Management Compliance	10
Glossary.....	11
Safety and Indemnity Notices	12
Safety.....	12
Indemnity	12
Indemnity	12

DMU02 Dynamics Measurement Unit

ABSOLUTE MAXIMUM RATINGS

Operating Temperature	-40°C to +85°C
Storage Temperature	-55°C to +125°C
Maximum Operating Voltage	6.0 V
Maximum Current on Start-up	300 mA
Power Supply Ripple Requirement	<5 mV pk-pk in frequency range 100 Hz to 12 kHz <2 mV pk-pk in frequency range 12 kHz to 400 MHz
Reverse Power Supply Protection	6 V for 1 second with a current limit of < 100 mA

NOTE: Stresses beyond those listed under Absolute Maximum Ratings may cause permanent damage to the device. These are stress ratings only and functional operation of the device at these or other conditions beyond those indicated is not implied.

NORMAL OPERATING RATINGS

Operating Temperature	-40°C to +85°C
Supply Voltage	5 V dc nominal, (4.75 V min, 5.25 V max continuous)
Supply Current	200 mA maximum at 5.25 V across operating temperature after 1 s start up

ESD SENSITIVITY

The DMU02 device is rated to BS EN 61000-4-2 Level 3 8kV.



ESD (Electrostatic Discharge) Sensitive Device

This product may be damaged by ESD. Such damage may result in subtle performance or life degradation, or complete device failure. Appropriate storage and handling precautions should be taken at all times to avoid ESD damage.

ENVIRONMENTAL REQUIREMENTS

Operational Vibration	0.04g ² /Hz	10Hz - 2kHz	(8.8grms)	*Note 1
Survival Vibration	0.25g ² /Hz	20Hz - 2.5kHz	(25grms)	
Operational Shock	95g 6ms			*Note 2
Survival Shock	1000g 1ms			
Do not drop onto a hard surface from a height exceeding 1000mm				
Humidity	35°C	85% RH	max	

RADIATED IMMUNITY BS EN61000-6-1

Electric field 10 V/m from 80 MHz to 2 GHz

RADIATED EMISSIONS BS EN61000-6-3

Frequency range 100 - 230 MHz - 30 dB(µV/m) at 10 m

Frequency range 230 - 1 GHz - 37 dB(µV/m) at 10 m

Note 1: Acceleration channels will saturate at axial inputs exceeding 6g pk.
 Note 2: Recovery from saturation in <20ms

SPECIFICATION

Angular rate function

PARAMETER	UNITS	VALUE
Scale factor	°/s/lb	0.03125
Full scale range	°/s	± 300
Scale factor over temperature (-40°C to +85°C)	%	± 2.5
Scale factor non linearity	% of FS	0.15
Bias over temperature	°/s	±2.5
Cross axis sensitivity	%	3
Bandwidth (-3dB) minimum	Hz	>40
Noise in band	°/s rms	<0.5

Linear acceleration function

PARAMETER	UNITS	VALUE
Scale factor	mg/lb	3.66
Full Scale range	g	± 6
Scale Factor sensitivity error (Vdd=5V ±5%, 23°C)	%	5
Scale Factor variation with temperature (-40°C to +85°C)	%	± 2
Scale Factor non linearity max	% of FS	0.5
Bias initial setting (at 23°C) max	mg	±250
Bias thermal gradient (-40°C to +85°C) max	mg/°C	±5.5
Offset Ratiometric error (Vdd=5V ±5%)	%	1.5
Cross axis sensitivity	%	4
Bandwidth (-3dB) minimum	Hz	400
Broadband Noise	mg rms	15

GENERAL PARAMETERS	UNITS	VALUE
Mass	gram	≤17
Start up time	ms	<500
Power supply	Volts	5 ±0.25
Current	mA	≤200
Operating temperature range	°C	-40°C to +85°C

NOTE: Specifications subject to change without notice.

DMU02 Dynamics Measurement Unit

PRODUCT DESCRIPTION

This section describes the DMU02 operation, angular rate measurements and linear acceleration measurements.

DMU02 Operation

The DMU02 comprises three rate sensors (gyroscopes) and accelerometers.

The normal mode of operation of the DMU02 provides inertial measurement data in the form of the Roll, Pitch and Yaw angular rates and the X, Y and Z linear accelerations. This data is aligned with the DMU02 co-ordinate set as defined in Figure 1 where arrow heads denote true acceleration.

Positive Roll, Pitch and Yaw angles (and angular rates) are defined as clockwise rotations when viewed along the positive X, Y and Z axis respectively.

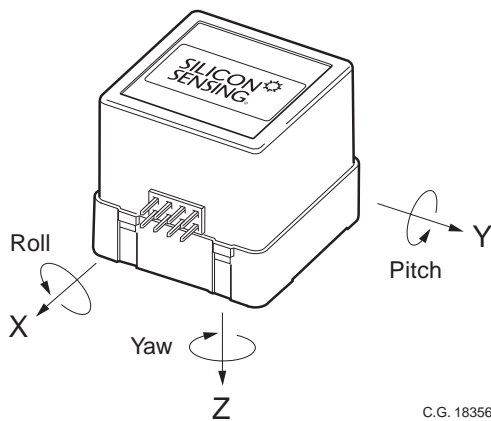

Figure 1 Co-ordinate Set for the DMU02 System

The DMU02 operates within 0.5 second from the application of power. The time at which power is applied is defined as the point in time when the DC voltage supplied to the DMU02 is within the range:

4.75V to 5.25V, nominal voltage 5V.

The DMU02 processes the sensor measurements at a maximum data rate of 3500 Hz (internal operation). Angular Rate and Linear Acceleration measurement data is available at a maximum data rate of 1.05 kHz per selected axis.

Mechanical Configuration

The physical outline of the DMU02 configuration is detailed in Figure 2.

Details of the mounting arrangements are shown in Figure 3.

Particular note should be taken of the torque settings for the locating screens and of the maximum dowel height.

Electrostatic handling precautions are required.

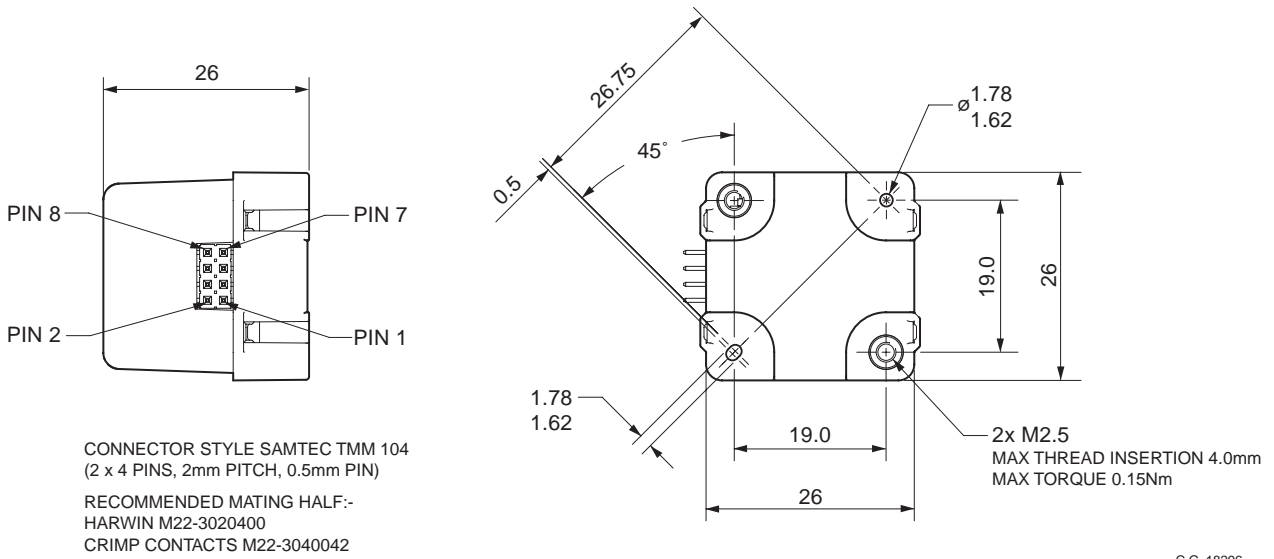

Figure 2 DMU02 Physical Outline

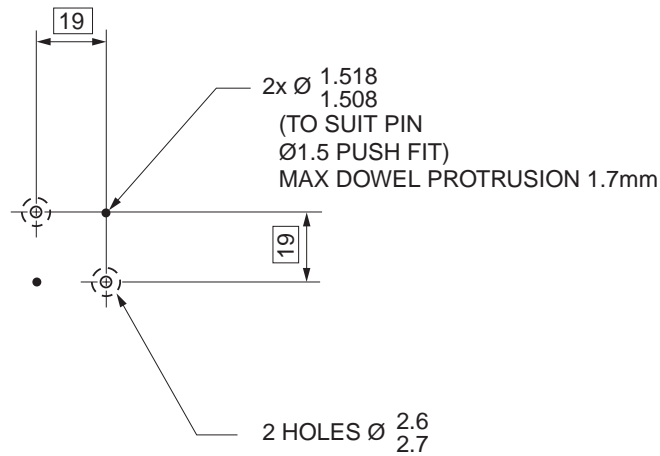

Figure 3 DMU02 Mounting Detail

Dimensions in mm

DMU02 Dynamics Measurement Unit

Product Labelling

The DMU02 unit is externally labelled with the Company Logo (Silicon Sensing), Product Name, Part Number, Serial Number, and Date of Manufacture.

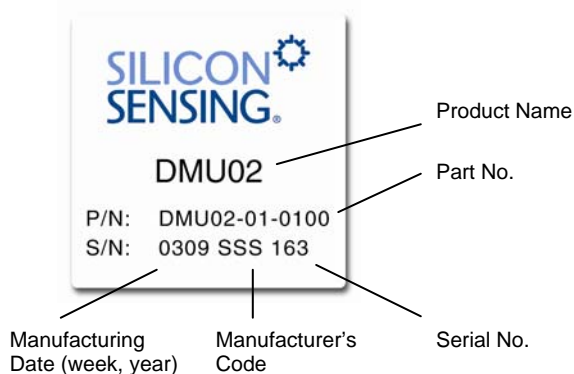

Figure 4 DMU02 Label

Connector pin-out

The interface connector on the DMU02 is an 8-pin Header (Samtec part no TMM-104-06-L-D-SM) with the following pin-out:

- Pin 1: Supply Positive
- Pin 2: MOSI
- Pin 3: MISO
- Pin 4: CLK
- Pin 5: GND
- Pin 6: S0 (Pitch rate, Y acceleration)
- Pin 7: S1 (Yaw rate, Z acceleration)
- Pin 8: S2 (Roll rate, X acceleration)

Note: Pin 1, Pin 2, Pin 7 and Pin 8 are identified in the Physical Outline illustration (Figure 2).

OPERATION AND TIMING SPECIFICATION

Serial Peripheral Interface Port

CAUTION: Attempted operation of the SPI port without Vdd being in range 5V ±0.25V is NOT RECOMMENDED.

The DMU02 supports a single SPI port shared between each axis, the SPI port consists of the four signals.

- CLK
- MOSI
- MISO
- SS (which can be either S0, S1 or S2), user selectable

The sharing of the single SPI port is arbitrated by three Slave Select (SS) lines, one for each axis, S0, S1 and S2. Only **one** SS can be active low at any one time. The permissible states are shown in Table 1.

Slave Select Permissible States

S0	S1	S2	Message content
1	1	1	Inactive
0	1	1	Pitch rate, Y acceleration
1	0	1	Yaw rate, Z acceleration
1	1	0	Roll rate, X acceleration

The message count for each axis consists of 6 bytes of 8 bits. The full duplex nature of the SPI bus means that each selected axis receives a command at the same time as it outputs the rate and acceleration data.

To communicate with each axis, the relevant SS must be selected. There must be a minimum of 7 µs delay between selecting different SS ports, see the illustrations below for details of these timings.

The table below gives the detailed timing information referenced from the illustrations below, which shows the details of the SPI port data structure.

SPI Port Timing Information

Parameter	Min Value	Max Value	Unit	Description
t _{CLK}	0.8		µs	CLK_IN period.
t ₁	5		µs	SPI_SEL to CLK_IN setup time.
t ₂	0.4 x t _{CLK}		µs	CLK_IN high pulse width.
t ₃	0.4 x t _{CLK}		µs	CLK_IN low pulse width.
t ₄	1.1		µs	Delay between successive bytes.
t ₅	7		µs	Delay between selecting SS lines. See Note 1
t _Q	730		µs	Minimum quiet time required between SPI_SEL rising and start of next communication. See Note 2
T _h	0		µs	SPI_SEL hold time after final clock
T _m	53.5	270	µs	Message duration. See Note 2
T _{tot}	950		µs	Repetition rate. See Note 2

Note 1: The toggling between the Slave Select will take a minimum of 7 µsec (t₅), the minimum time between the toggling of successive Slave Selects is t₅+T_{tot}

Note 2: A quiet time (t_q) between messages is required, and 3x(t₁ + T_m + T_h) + t_q = T_{tot}. Optimum performance is achieved with a repetition rate of 1ms. Select an appropriate T_{clk} to meet the requirements of T_m, and then adjust t_q to give a T_{tot} of 1ms.

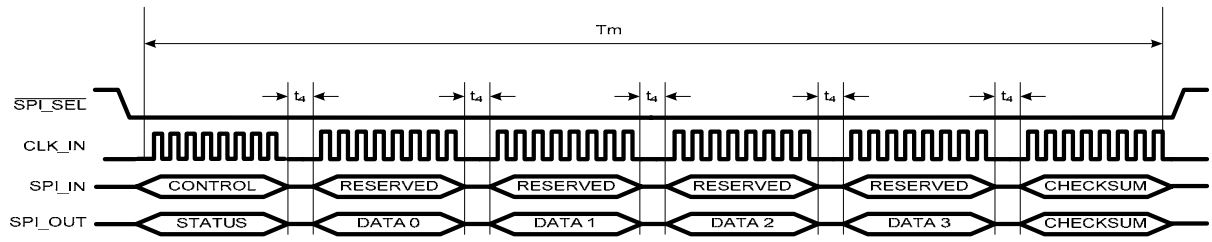

Figure 5 SPI Data Timing Diagram

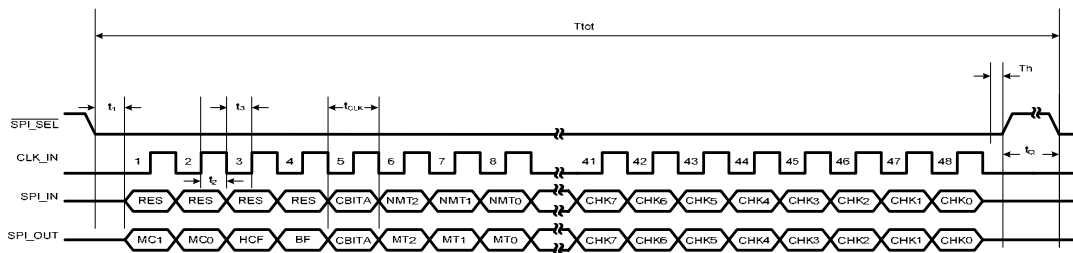
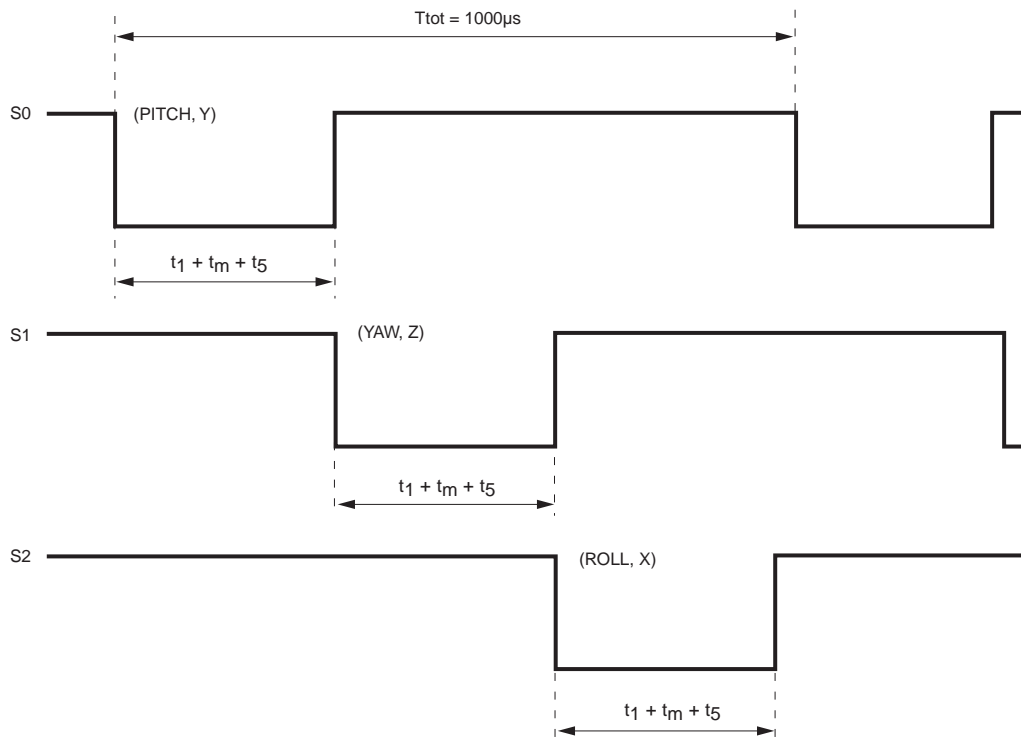

Figure 6 SPI Data Frame Structure



C.G. 18351

Figure 7 SS (Slave Selection) Timing

DMU02 Dynamics Measurement Unit



External System to DMU02 Messages

The data frames from the external system for each axis of the DMU02 are in the following format:

Byte	Function
0	Control Byte
1	Reserved
2	Reserved
3	Reserved
4	Reserved
5	Checksum

Control Byte:

RES	RES	RES	RES	CBITA	NMT2	NMT1	NMT0
bit 7				bit 0			

bit 7-4 **RES** : Reserved
Set to 0

bit 3 **CBITA** : Commanded Built In Test A
0 = Deactivate CBIT_A test
1 = Activate CBIT_A test (see CBITA function)

bit 2-0: **NMT2:NMT0** : Next Message Type
000 = Reserved
001 = Rate and Accelerometer sensor data
010 = Reserved
011 = Rate and Temperature sensor data
100 = Device Configuration 1 data
101 = Device Configuration 2 data
110 = Reserved
111 = Reserved

Reserved:

RES	RES	RES	RES	RES	RES	RES	RES
bit 7				Bit 0			

bit 7-0 **RES** : Reserved
Set to '00' hex

Checksum:

CHK7	CHK6	CHK5	CHK4	CHK3	CHK2	CHK1	CHK0
bit 7				Bit 0			

bit 7-0 **CHK7:CHK0** : Checksum
1's complement of the sum of bytes 0 – 4 (previous 5 bytes)

Note: If an incorrect message is received, the DMU02 axis selected will continue to transmit the message chosen in the last valid request.

Upon power up, the DMU02 will output the device configuration 1 message for all three axes until a valid control message is received on each axis.

DMU02 to External System Messages

The data frames transmitted from the DMU02 to the external system are in the following format:

Byte	Function
0	Status Byte
1	Data 0 MSB (Rate)
2	Data 1 LSB (Rate)
3	Data 2 MSB (Accelerometer)
4	Data 3 LSB (Accelerometer)
5	Checksum

Each message from the DMU02 begins with a status byte contained in byte 0 and a checksum in byte 5. For all messages the following format is adopted, Bytes 0 to 4 are 2's compliment and Byte 5 is 1's compliment.

Status Byte:

MC1	MC0	HCF	BF	CBITA	MT2	MT1	MT0
bit 7				bit 0			

bit 7-6 **MC1:MC0** : Message Count
Incremented by the DMU02 each time the host system takes a message.

bit 5 **HCF** : Host communications fault
0 = No fault detected
1 = Communications fault detected

bit 4 **BF** : Built in test (BIT) fault
0 = Gyro output OK
1 = BIT Failure

bit 3 **CBITA** : CBITA active
0 = CBIT_A test inactive
1 = CBIT_A test in progress

bit 2-0 **MT2:MT0** : Message type
000 = Reserved
001 = Rate and Accelerometer
010 = Reserved
011 = Rate and Temperature sensor data
100 = Reserved
101 = Reserved

Checksum:

CHK7	CHK6	CHK5	CHK4	CHK3	CHK2	CHK1	CHK0
bit 7				bit 0			

bit 7-0 **CHK7:CHK0** : Checksum
1's complement of the sum of bytes 0 – 4

Depending on the message type requested in NMT2:NMT0, the previous control byte from the host, the data bytes (*Data 3: Data 0*) in the subsequent data frame from the DMU02 contains the following data, indicated by NMT2:NMT0:

Device Configuration 1 Message (NMT2:NMT0 = 100) – Default on power up

Byte	Function	Description
0	Status Byte	
1	Bits (7:4) Bits (3:0)	Model rate range (e.g. 3 = 75°/s) Model bandwidth (e.g. 1 = 100Hz)
2	Bits (7:4) Bits (3:0)	Spare bits Model variant
3	Software Version	Software variant number
4	Bits (7:5) Bits (4:0)	Spare bits Year of manufacture
5	Checksum	

The Device Configuration 1 Message is the first message sent for each channel after that channel is selected

Device Configuration 2 Message (NMT2:NMT0 = 101)

Byte	Function	Description
0	Status Byte	
1	Bits (7:4) Bits (3:0)	Month of manufacture (3:0) Package lot number (11:8)
2	Bits (7:0)	Package lot number (7:0)
3	Bits (7:6) Bits (5:0)	Assembly plant (1:0) Device serial number (13:8)
4	Bits (7:0)	Device serial number (7:0)
5	Checksum	

Note: The contents of the two device configuration messages give each sensor a unique serial number.

Note: If an incorrect message is received, the DMU02 will continue to transmit the message chosen in the last valid request. Upon power up, the DMU02 will output the Device Configuration 1 message until a valid control signal is received.

Rate and Acceleration Message (NMT2:NMT0 = 001)

Byte	Function	Description
0	Status Byte	
1	Rate MS	Nominally $\pm 350^\circ/\text{s}$ FS 0.03125 $^\circ/\text{s}/\text{lsb}$
2	Rate LS	
3	Accelerometer MS	3.66 mg/lsb
4	Accelerometer LS	
5	Checksum	

Rate and Temperature Sensor Message (NMT2:NMT0 = 011)

Byte	Function	Description
0	Status Byte	
1	Rate MS	Nominally $\pm 350^\circ/\text{s}$ FS 0.03125 $^\circ/\text{s}/\text{lsb}$
2	Rate LS	
3	Temperature MS	-50 $^\circ\text{C}$ to 145 $^\circ\text{C}$, 0.125 $^\circ\text{C}/\text{lsb}$
4	Temperature LS	
5	Checksum	

A typical message from the DMU02 to the external system could take the following form (output in Hex).

The status byte is a cyclic counter, and for the control byte of 01h sent, the returned status byte will be 01h after the first cycle, 41h for the second cycle 81h for the third cycle and a C1h for the last cycle. This message count is repeated each time the message counter is updated e.g. 01, 41h,81h, C1h, 01h, 41h, 81h.....

If the control byte 03h is sent, then the status byte returned would be, 03h, 43h, 83h C3h, 03h, 43h, 83h.....

For a Control byte sent 01h (Rate and Acceleration Data).

Status message returned after 1 cycle:

Byte 0	Byte 1	Byte 2	Byte 3	Byte 4	Byte 5
01	22	60	02	F4	86

This equates to a rate of 275 $^\circ/\text{s}$ (bytes 1 and 2) and an acceleration of 2.8g (bytes 3 and 4). This would be repeated for the 3 axes.

The message could take the following format for Slave 0:

Byte 0	Byte 1	Byte 2	Byte 3	Byte 4	Byte 5
41	1F	40	02	9A	C3

This equates to a rate of 250 $^\circ/\text{s}$ (bytes 1 and 2) and an acceleration of 2.4g (bytes 3 and 4).

For Slave 1:

Byte 0	Byte 1	Byte 2	Byte 3	Byte 4	Byte 5
81	F1	00	00	D8	B5

This equates to a rate of -120 $^\circ/\text{s}$ (bytes 1 and 2) and an acceleration of 0.8g (bytes 3 and 4).

And for Slave 2:

Byte 0	Byte 1	Byte 2	Byte 3	Byte 4	Byte 5
C1	09	60	FE	08	CF

This equates to a rate of 75 $^\circ/\text{s}$ (bytes 1 and 2) and an acceleration of -1.9g (bytes 3 and 4).

Self Test Capability

During operation, each rate axis of the DMU02 is checked for signal integrity. The CBITA command can be used to place each selected axis of the DMU02 into self test mode.

CBITA Function (Command BIT 3)

CBITA (Software Command) is only applicable to the Rate channels (Pitch, Yaw and Roll axis); there is no self test for the Acceleration channels.

The DMU02 has the ability to carry out a commanded built in test (CBITA) on each channel independently. This is used as a test to ensure the device is functioning correctly by exercising the rate MEMS structure, the rate sensing loops and drive and the pickoff electronics. CBITA works by applying an offset to the loops running inside the rate sensor, which results in a 10 $^\circ/\text{s}$ offset bias in the rate output. The timing of the offset in relation to the state of the CBITA command is shown in Figure 8.

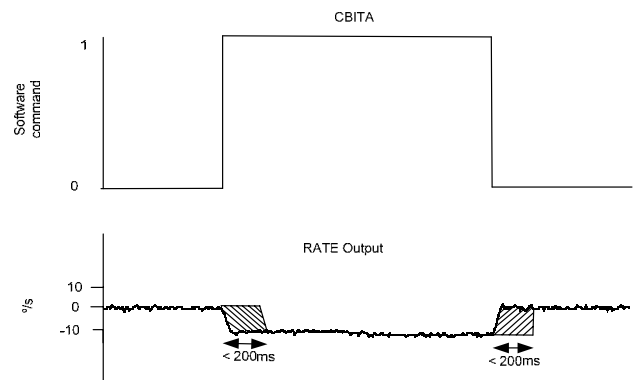

Figure 8 CBITA Timing

CBITA Logic Levels

- CBITA = 0 The CBITA test will be disabled.
- CBITA = 1 The DMU02 will initiate a CBITA test, in which a nominal offset bias of 10 $^\circ/\text{s}$ will be applied to the rate output of the SPI port selected.

Product Environmental Management Compliance

The DMU02 complies with the requirements of the RoHS and WEEE directives.

GLOSSARY

A	Amperes
BIT	Built-in-Test
CLK	Clock
CofG	Centre of Gravity
COSHH	Control Of Substances Hazardous to Health
COTS	Commercial off the Shelf
DMU02	SSS Dynamics Measurement Unit
DOF	Degrees of Freedom
ESD	Electrostatic Discharge
GND	Ground
ISO	International Organisation for Standardisation
LSB	Least Significant Byte
MISO	Master Input, Slave Output
MOSI	Master Output, Slave Input
MS	Microsoft®
MSB	Most Significant Byte
RoHS	Restriction of Hazardous Substances
RMS	Root Mean Square
ROW	Rest of the World
SPI	Serial Peripheral Interface
TBA	To Be Agreed
TBD	To Be Determined
USB	Universal Serial Bus
WEEE	The Waste Electrical and Electronic Equipment Directive
XYZ	Linear Acceleration Measurements in X, Y and Z (g) Axes

SAFETY AND INDEMNITY NOTICES

Safety

The DMU02 has not been designed for use in safety critical applications.

The DMU02 provides inertial information in terms of angular rate and linear acceleration. This information is provided in a digital format. No checks are performed within the DMU02 on the correctness or integrity of the data sent. The integrity of this digital information shall be considered at the next highest assembly and appropriate actions taken at that level.

The DMU02 shall be provided with electrical power from a low voltage supply. The internal electronics of the DMU02 shall operate from the low voltage supply and shall not produce any hazardous voltages.

The DMU02 is designed to be low maintenance.

The DMU02 has no sharp edges.

The DMU02 does not contain any hazardous materials as defined in both the UK and European legislation.

The DMU02 is marked indicating that it could be susceptible to electrostatic discharge damage and that any documentation supplied shall state that precautions for handling electrostatic sensitive devices shall be followed.

The product should not be used in any application where any undetected functional or other failure or performance deterioration would cause a safety hazard, including but not limited to hazards caused by EMC susceptibility or emissions.

Indemnity

Indemnity

Indemnity Notice SE Asia, ROW

User and/or Purchaser (Customer) shall indemnify and hold Silicon Sensing Systems Japan Limited ("SSSJL"), Silicon Sensing Systems Limited ("SSSL") and its affiliates, including its members, shareholders, managers, directors, officers, employees, agents and representatives, harmless from and against any and all liabilities, claims, demands, actions, costs or expenses (including all reasonable legal or litigation costs), by whomever asserted and regardless of nature or kind, including without limitation and/or product liability claims arising from the use of any product supplied by SSSJL ("Product") to (Customer), claims for personal injuries (including death) and damage to property, whether in tort or under contract, directly or indirectly, in whole or in part, attributed to or arising from the use by (Customer) of any Product supplied by SSSJL to (Customer) for any purpose (whether relating to any defect in material, workmanship or design) including but without limitation, installing the Product on a product, equipment or vehicle of any kind, or using the Product for training or simulation purposes in relation to a product, equipment or vehicle of any kind, or using the Product for the support and maintenance of a product, equipment or vehicle of any kind. SSSJL shall promptly notify (Customer) of any such claim for which an indemnity will be sought. (Customer) shall have the right at its expense to assume control the defence of such claims and SSSJL shall provide reasonable co-operation and information to (Customer) in order for (Customer) to defend the claims. (Customer) may not settle any such claim without the prior written consent of SSSJL, which consent may not be unreasonably withheld. Product supplied by SSSJL is not warranted in any way for any period regardless of the existing laws and/or regulations unless agreed in writing by and between SSSJL and (Customer) prior to purchasing the Product. SSSJL, SSSL or its affiliates reserve the right to make changes without further notice to any Products herein. SSSJL, SSSL or its affiliates make no warranty, representation or guarantee regarding the suitability of its Products for any particular purpose, nor does SSSJL, SSSL or its affiliates assume any liability arising out of the application or use of any product or circuit, and specifically disclaims any and all liability, including without limitation indirect, consequential or incidental damages. "Typical" parameters which may be provided in SSSJL datasheets and/or specifications can and do vary in different applications and actual performance may vary over time. All operating parameters, including "Typical" must be validated for each customer application by customer's technical experts. SSSJL does not convey any licence under its patent rights nor the rights of others.

Indemnity Notice Europe, USA, ROW

User and/or Purchaser (Customer) shall indemnify and hold Silicon Sensing Systems Limited ("SSSL") and its affiliates, including its subsidiaries, members, shareholders, managers, directors, officers, employees, agents and representatives, harmless from and against any and all liabilities, claims, demands, actions, costs or expenses (including all reasonable legal or litigation costs), by whomever asserted and regardless of nature or kind, including without limitation and/or product liability claims arising from the use of any product supplied by SSSL ("Product") to (Customer), claims for personal injuries (including death) and damage to property, whether in tort or under contract, directly or indirectly, in whole or in part, attributed to or arising from the use by (Customer) of any Product supplied by SSSL to (Customer) for any purpose (whether relating to any defect in material, workmanship or design) including but without limitation, installing the Product on a product, equipment or vehicle of any kind, or using the Product for training or simulation purposes in relation to a product, equipment or vehicle of any kind, or using the Product for the support and maintenance of a product, equipment or vehicle of any kind. SSSL shall promptly notify (Customer) of any such claim for which an indemnity will be sought. (Customer) shall have the right at its expense to assume control the defence of such claims and SSSL shall provide reasonable co-operation and information to (Customer) in order for (Customer) to defend the claims. (Customer) may not settle any such claim without the prior written consent of SSSL, which consent may not be unreasonably withheld. Product supplied by SSSJL is not warranted in any way for any period regardless of the existing laws and/or regulations unless agreed in writing by and between SSSL and (Customer) prior to purchasing the Product. SSSL reserves the right to make changes without further notice to any products herein. SSSL makes no warranty, representation or guarantee regarding the suitability of its products for any particular purpose, nor does SSSL assume any liability arising out of the application or use of any product or circuit, and specifically disclaims any and all liability, including without limitation consequential or incidental damages. "Typical" parameters which may be provided in SSSL datasheets and/or specifications can and do vary in different applications and actual performance may vary over time. All operating parameters, including "Typical" must be validated for each customer application by customer's technical experts. SSSL does not convey any licence under its patent rights nor the rights of others.



+44 1752 723330 • Fax: +44 1752 723331

+81 6 6489 5868 • Fax: +81 6 6489 5910

+1 203 250 3699 • Fax: +1 203 250 8047

sales@siliconsensing.com • www.siliconsensing.com